

STRAFIX PIPE SUPPORTS

DESCRIPTION

The part has a toothed profile to support the pipe, moulded onto a steel strap. There are 3 different profiles depending on the diameter of the pipe to be supported. The elastomer is available in either chloroprene or non flammable silicone.

Advantages :

With only 3 different parts it is possible to provide vibration isolation to pipes with \varnothing 6 up to 206,5 mm. Cutting and shaping the STRAFIX to suit the pipes is easy.

CHARACTERISTICS PROFILE BEFORE MOUNTING

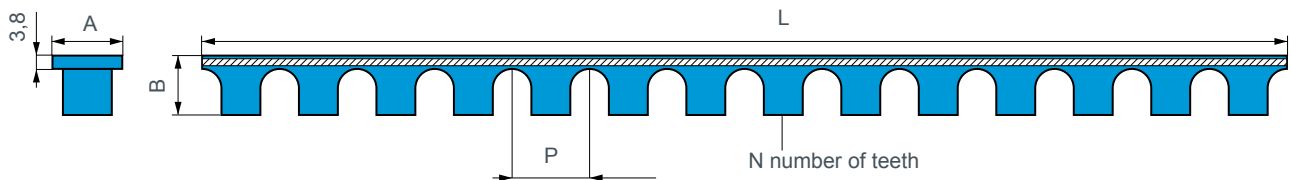

Designations & references	Strafix G1	Strafix G2	Strafix G3
Ref. non flammable silicon	E 4286 F01	E 4287 F01	E 4288 F01
Ref. Chloroprene	E 4286 F02	E 4287 F02	E 4288 F02

Strafix	Dimensions (mm) PROFILE BEFORE MOUNTING		
	G1	G2	G3
Width A	15	20	35
Height B	12	17	17
Pas P (1 pitch)	16,71	22,2	38,28
Lenght L	501,3	666	842,16
Number of teeth	30	9	22

Strafix	Dimensions (mm) PROFILE AFTER MOUNTING		
	G1	G2	G3
\varnothing Pipe minimum	6	16	51
\varnothing Pipe maximum	42 approx.	94,9 approx.	206,5 approx.
Housing diameter	approx. DE+20	approx. DE+30	approx. DE+30

STRAFIX AFTER MOUNTING

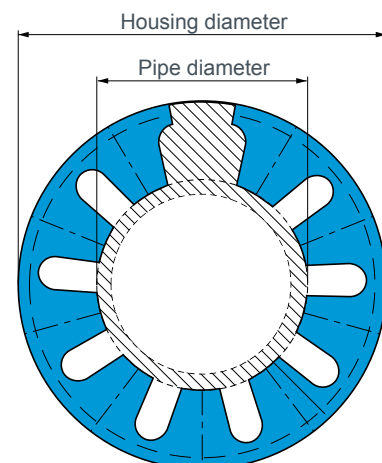

STRAFIX AFTER MOUNTING



MECHANICAL CHARACTERISTICS

- Maximum dynamic amplitude in all directions : $\pm 0,5$ mm
- CR : Max static radial load.
- CA : Max static axial load : 20% of CR
- Max strength under shock :
 - axial = 4 x CA;
 - radial = 10x CR.

STRAFIX G1

Pipe diameter DE (mm)	Number of teeth	Radial load (daN)	Radial Kdyn (N/mm)	Axial Kdyn (N/mm)
6 - 10,1	4	0,67	10	1,6
10,2 - 15,5	5	0,83	12,5	2
15,6 - 20,8	6	1	15	2,4
20,9 - 26,1	7	1,17	17,5	2,8
26,2 - 31,4	8	1,34	20	3,2
31,5 - 36,7	9	1,5	22,5	3,6
36,8 - 42,1	10	1,67	25	4

STRAFIX G2

Pipe diameter DE (mm)	Number of teeth	Radial load (daN)	Radial Kdyn (N/mm)	Axial Kdyn (N/mm)
16 - 17,1	5	6,6	90	14,4
17,2 - 24,2	6	7,9	108	17,3
24,3 - 31,3	7	9,2	126	20,16
31,4 - 38,3	8	10,6	144	23,04
38,4 - 45,4	9	11,9	162	25,92
45,5 - 52,5	10	13,2	180	28,8
52,6 - 59,5	11	14,5	198	31,68
59,6 - 66,6	12	15,8	216	34,56
66,7 - 73,7	13	17,2	234	37,44
73,8 - 80,7	14	18,5	252	40,32
80,8 - 87,8	15	19,8	270	43,2
87,9 - 94,9	16	21,1	288	46,08

STRAFIX G3

Pipe diameter DE (mm)	Number of teeth	Radial load (daN)	Radial Kdyn (N/mm)	Axial Kdyn (N/mm)
51 - 60,2	6	61	915	146
60,3 - 72,4	7	71,2	1068	171
72,5 - 84,6	8	81,3	1220	195
84,7 - 96,8	9	91,5	1372	220
96,9 - 109	10	101,7	1525	244
109,1 - 121,2	11	112	1678	268
121,3 - 133,4	12	122	1830	293
133,5 - 145,5	13	132	1983	317
145,6 - 157,7	14	142	2135	342
157,8 - 169,9	15	152	2288	366
170 - 182,1	16	163	2440	390
182,2 - 194,3	17	173	2593	415
194,4 - 206,5	18	183	2745	439

